

Applications

1. Cut a sheet of paper in half so you have two identical half-sheets of paper. Tape the long sides of one sheet together to form a cylinder. Tape the short sides from the second sheet together to form another cylinder. Suppose that each cylinder has a top and a bottom.



- a. Which cylinder has the greater volume? Explain.
 - b. Which cylinder has the greater surface area? Explain.
2. A cylinder has a radius of 3 centimeters. Sand is poured into the cylinder to form a layer 1 centimeter deep.
 - a. What is the volume of sand in the cylinder?
 - b. Suppose the height of the cylinder is 20 centimeters. How many 1-centimeter deep layers of sand are needed to fill the cylinder?
 - c. What is the volume of the cylinder?
 3. Find a cylindrical object in your home or school. Record the dimensions and find the volume of the cylinder.

For Exercises 4–6, decide whether you have found an area, a surface area, or a volume. Then, identify whether the computation relates to Figure 1, 2, or 3.

4. $\left(\frac{1}{2} \times \frac{1}{2} \times \pi \times 2\right) + \left(2 \times \frac{1}{2} \times \pi \times 5\right)$

5. $3 \times 3 \times \pi$

6. $1 \times 1 \times \pi \times 3$

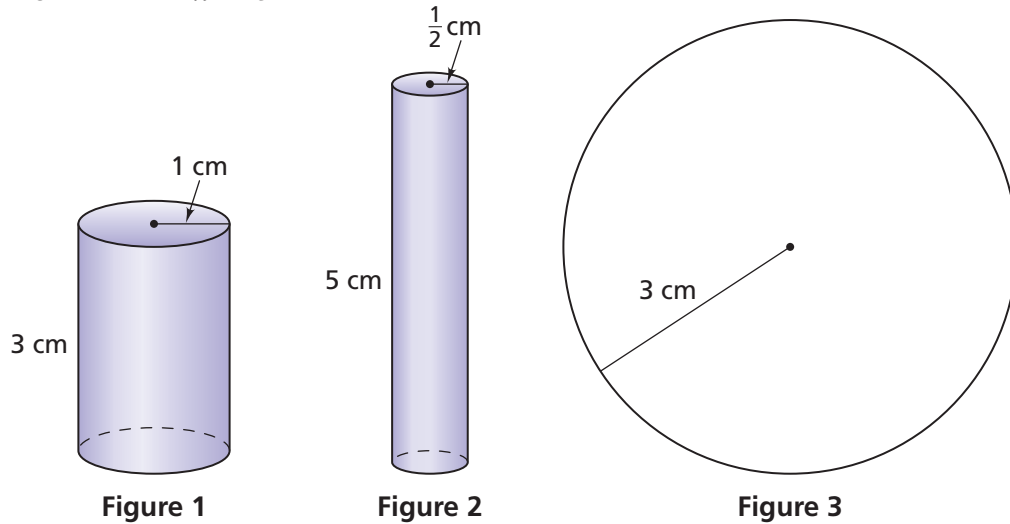

7. A pipeline carrying oil is 5,000 kilometers long and has an inside diameter of 20 centimeters.
- How many cubic centimeters of oil will it take to fill 1 kilometer of the pipeline? (1 km = 100,000 cm)
 - How many cubic centimeters of oil will it take to fill the entire pipeline?

Homework Help Online
PHSchool.com
 For: Help with Exercise 7
 Web Code: ane-6307



8. What feature of a cylinder uses the given units?
- a. centimeters
 - b. square centimeters
 - c. cubic centimeters

For Exercises 9–11, find the volume of each cylinder.

9. height = 10 centimeters, radius = 6.5 centimeters
10. height = 6.5 centimeters, radius = 10 centimeters
11. height = 12 inches, area of the base = 200 square inches
12. Find the surface area of each closed cylinder in Exercises 9 and 10.
13. a. Will all rectangular prisms with the same height and base area have the same shape? Explain.
b. Will all cylinders with the same height and base area have the same shape? Explain.
14. A cylindrical storage tank has a radius of 15 feet and a height of 30 feet.
a. Make a sketch of the tank and label its dimensions.
b. Find the volume of the tank.
c. Find the surface area of the tank.
15. a. Sketch two different prisms, each with a base of area 40 square centimeters and a height of 5 centimeters.
b. Find the volumes of your prisms.
c. Do you think everyone in your class drew the same prisms? Explain.
d. Do you think all the prisms have the same volumes as your prisms? Explain.



For: Multiple-Choice Skills
Practice
Web Code: ana-6354



- 16.** Below are side and top views of a triangular prism with bases that are equilateral triangles.
- What is the volume of this prism? How did you find the volume?
 - What is the surface area? How did you find the surface area?

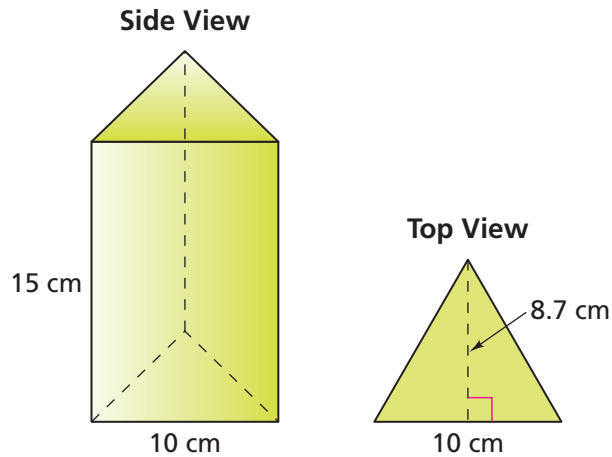

- 17.** Below is a scale model of a net for a cylinder.

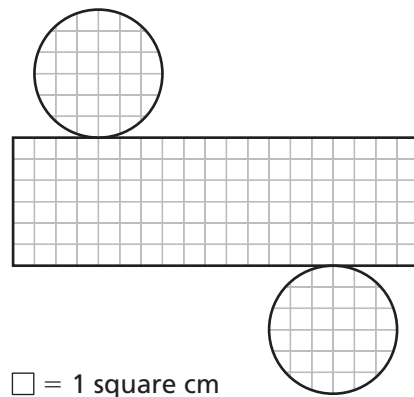

- Suppose the net is assembled. Find the volume of the cylinder.
 - Find the surface area of the cylinder.
- 18.** Which container below has the greater volume? Greater surface area?
- A closed rectangular prism* whose height is 12 centimeters, width is 3 centimeters, and length is 4 centimeters.
- A closed cylinder* whose height is 12 centimeters and diameter is 3 centimeters.

- 19.** The bases of the prisms you made in Problem 3.1 are shown at the right. Each prism has a height of 8.5 inches.
- Compute the volume of each prism.
 - Compare these volumes with those you found in Problem 3.1.

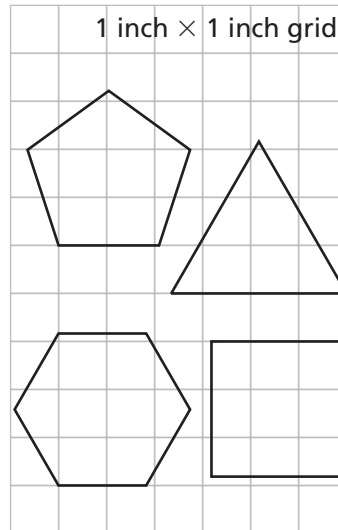

- 20.** Carlos wants to build a circular hot tub with a volume of 1,000 cubic feet. What is a good approximation for the radius of the tub?

- 21.** Carlos decides he would rather build a rectangular hot tub that is 4 feet high and holds 400 cubic feet of water. What could the dimensions of the base of Carlos's hot tub be?

- 22.** A popcorn vendor needs to order popcorn boxes. The vendor must decide between a cylindrical box and a rectangular box.

- The cylindrical box has a height of 20 centimeters and a radius of 7 centimeters.
 - The rectangular box has a height of 20 centimeters and a square base with 12-centimeter sides.
 - The price of each box is based on the amount of material needed to make the box.
 - The vendor plans to charge \$2.75 for popcorn, regardless of the shape of the box.
- Make a sketch of each box. Label the dimensions.
 - Find the volume and surface area of each box.
 - Which box would you choose? Give the reasons for your choice. What additional information might help you make a better decision?



Connections

23. Serge and Jorge were talking about the number π . Serge said that any problem involving π had to be about circles. Jorge disagreed and showed him the example below. What do you think?



24. The Buy-and-Go Mart sells drinks in three sizes. Which size gives the most ounces of drink per dollar? Explain.

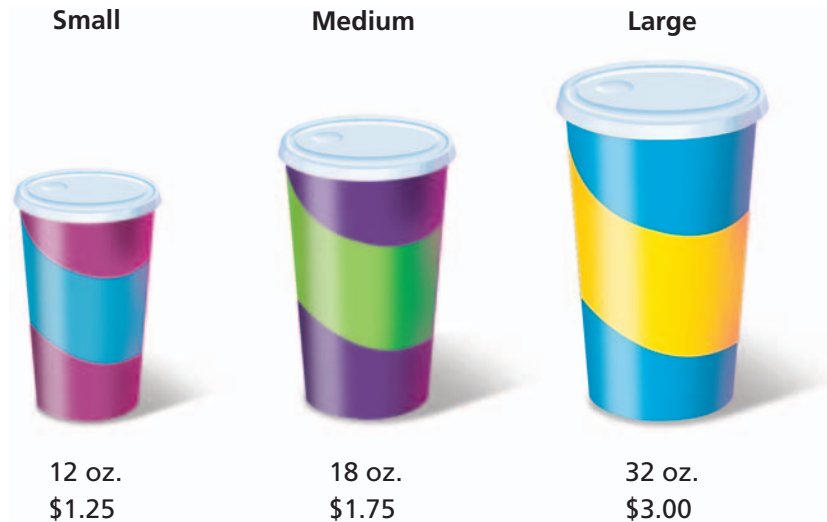

25. **a.** Identify objects at school that are shaped like prisms, one rectangular and one or two non-rectangular prisms.
b. Without measuring, estimate the volume of each object.
c. How can you check the volumes you found in part (b)?
26. A drink can is a cylinder with radius 3 centimeters and height 12 centimeters. Ms. Doyle's classroom is 6 meters wide, 8 meters long, and 3 meters high. Estimate the number of drink cans that would fit inside Ms. Doyle's classroom. Explain your estimate.

- 27. a.** Make a table showing the relationship between the diameter and the circumference of a circle. Include data for diameters 1, 2, 3, . . . 10 centimeters. Use this table for parts (b)–(d).
- b.** Graph the data in your table.
- c.** Suppose that each of the circles represented in your table is the base of a cylinder with height of 2 centimeters. Some of these cylinders are sketched below. Make a table to show the relationship between the diameter of the base and the volume of the cylinder.

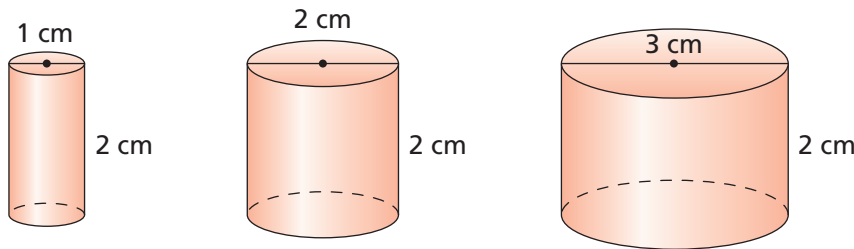

- d.** Make a graph of the volume data.
- e.** Compare the graphs of parts (b) and (d). How are they alike? How are they different?
- 28.** Some take-out drink containers have a circular top and bottom that are not congruent. How can you estimate the volume of the container below?

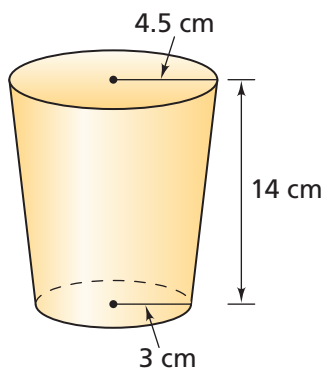

- 29.** Leo has two prism-shaped containers. One has a volume of $3\frac{3}{4}$ cubic feet and the other has a volume of $\frac{1}{3}$ cubic feet.
- a.** How many of the smaller prisms would it take to fill the larger prism?
- b.** What operation did you use to find the answer? Explain.
- 30.** Emily has two prism-shaped containers. One has a volume of $2\frac{2}{5}$ cubic feet, and the other has a volume of $\frac{2}{3}$ cubic feet.
- a.** How many of the smaller prisms would it take to fill the larger prism?
- b.** What operation did you use to find the answer? Explain.

- 31.** The diagram shows a fish tank after a container of water is poured into the tank.

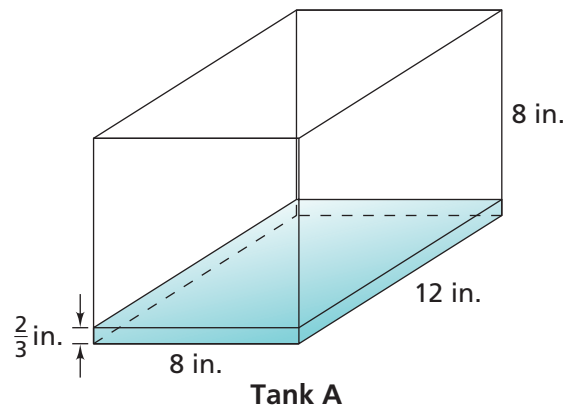

- a. How many containers of water are needed to fill the tank?
 - b. What fraction of the tank does the container fill?
 - c. A different container holds $12\frac{3}{4}$ cubic inches of water. How many of these containers are needed to fill the tank?
- 32.** The diagram shows a fish tank after a container of water is poured into the tank.

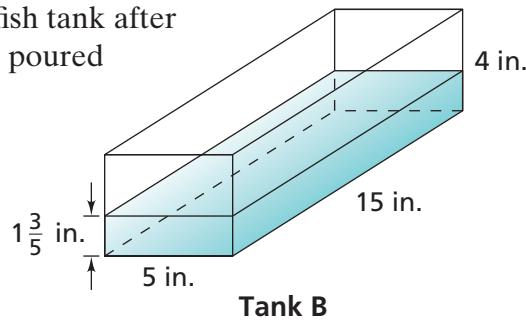

- a. How many containers of water are needed to fill the tank?
- b. What fraction of the tank does the container fill?
- c. A different container holds $4\frac{4}{9}$ cubic inches of water. How many of these containers are needed to fill the tank?



Extensions

33. A cylindrical can is packed securely in a box as shown at the right.

- Find the radius and height of the can.
- What is the volume of the empty space between the can and the box?
- Find the ratio of the volume of the can to the volume of the box.
- Make up a similar example with a can and a box of different sizes. What is the ratio of the volume of your can to the volume of your box? How does the ratio compare with the ratio you found in part (c)?

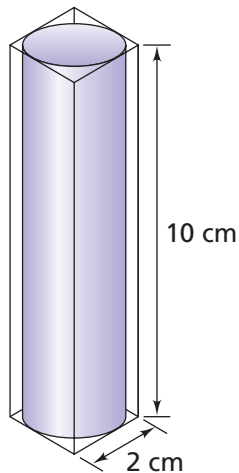

34. a. The drawing at the right shows a prism with an odd-shaped top and bottom and rectangular sides. The top and bottom each have an area of 10 square centimeters, and the height is 4 centimeters. What is the volume of the prism? Explain your reasoning.

- Is your estimate for the volume more than, less than, or equal to the exact volume? Explain.

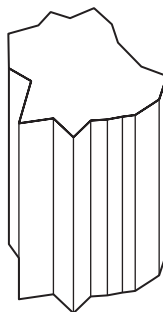

35. Suppose you know the height and volume of a cylinder. Can you make a net for the cylinder?